Production: **Airence 6D to 6E Memo**

Cause:

The Airence-6D PCB is updated to the Airence-6E PCB due to an improvement of the circuitry. Customer complains leading to this improvement are leakage between audio announcer phones and studio output. Also a fault in rev D on R57 is solved in Rev E.

Additional Info

To solve the audio leakage an extra muting circuit is added to the announcer output. Also the switches circuits controlling the talkback mic are made separately. The TB_MUTE signal is now only fed through its corresponding muting circuit only when the TB switch is selected.

Rev D and E board are inter exchangeable !

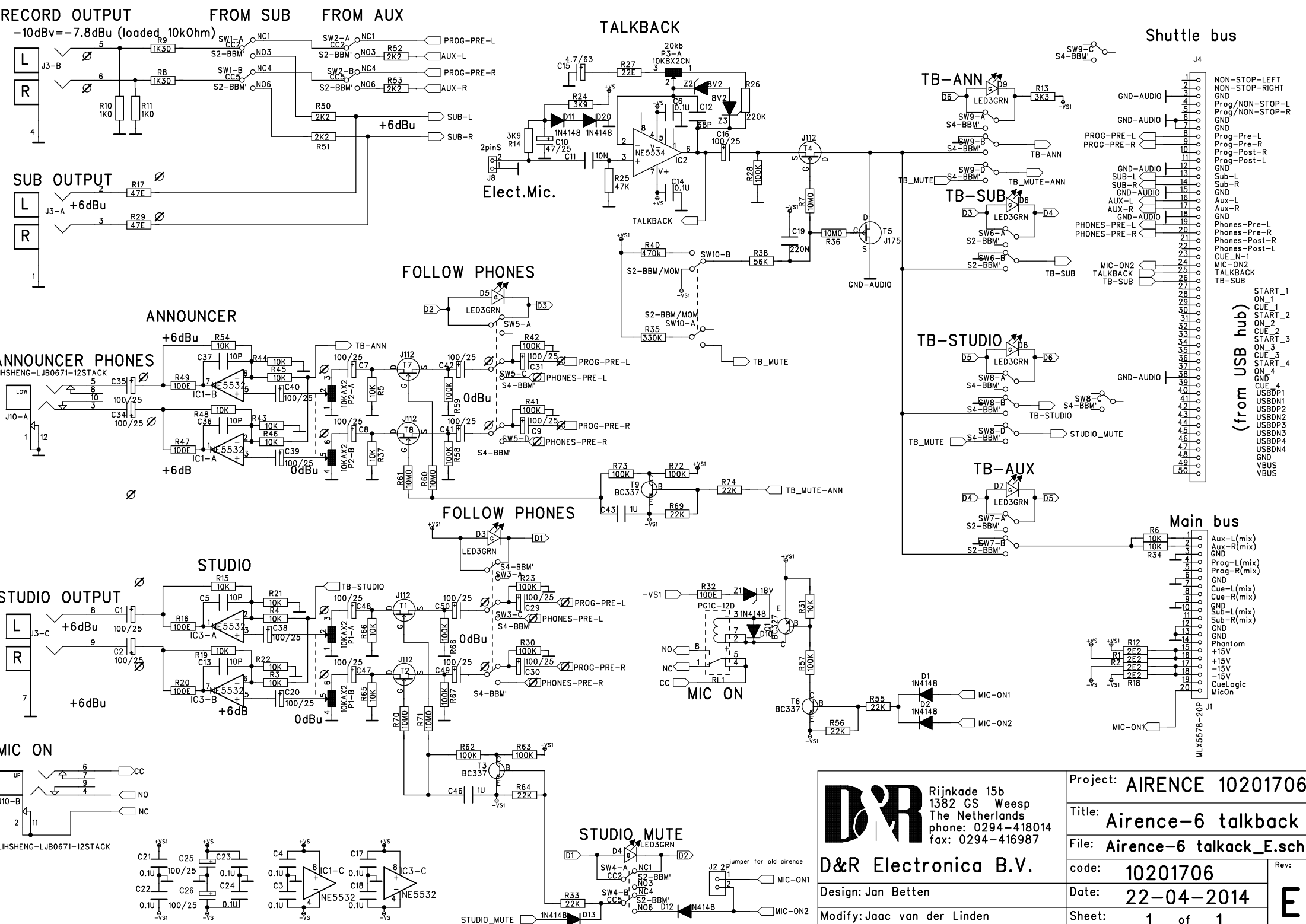

D&R Rijnkade 15b
 1382 GS Weesp
 The Netherlands
 phone: 0294-418014
 fax: 0294-416987

D&R Electronica B.V.

Design: Jan Betten

Modify: Jaac van der Linden

Project: AIRENCE 10201706

Title: Airence-6 talkback

File: Airence-6 talkack_E.sch

code: 10201706

Date: 22-04-2014

Sheet: 1 of 1

Rev: **E**

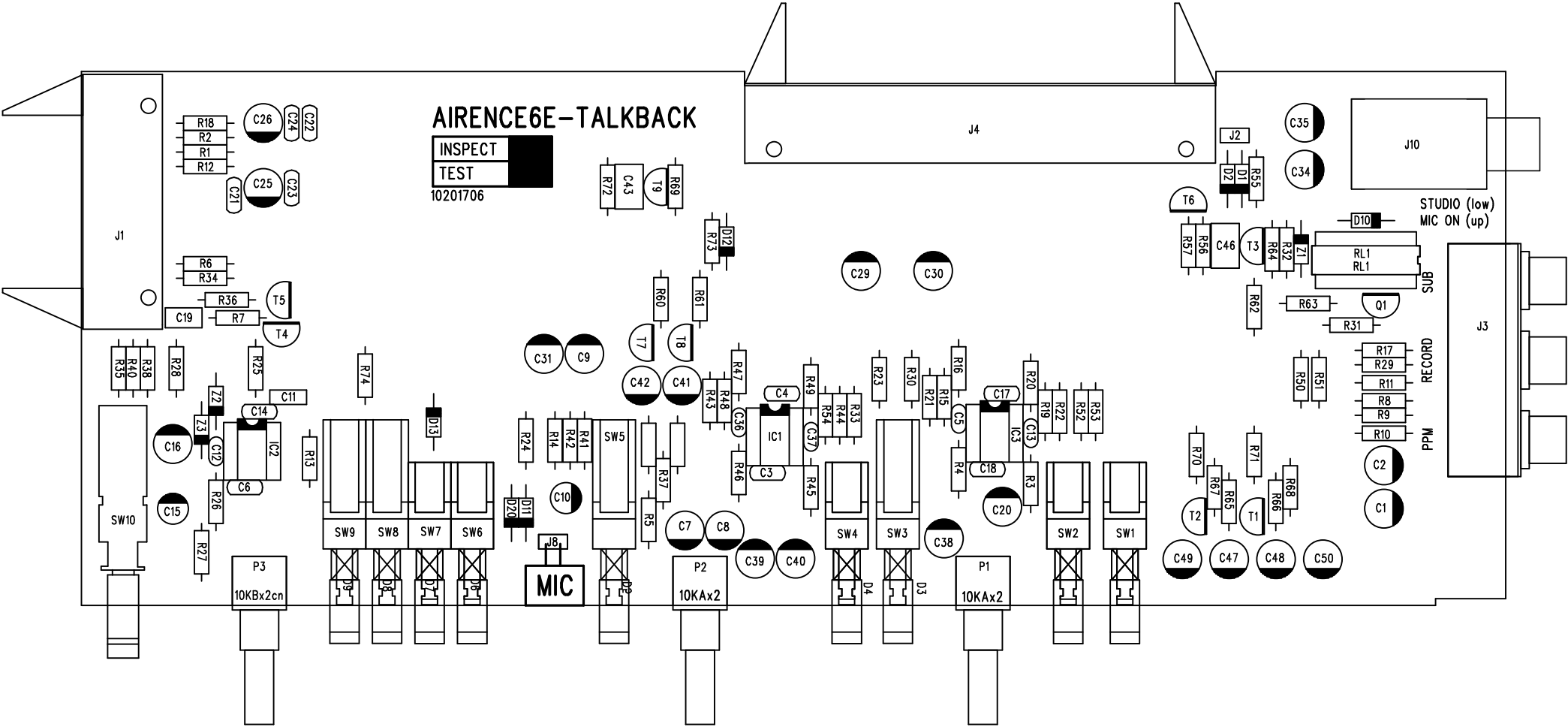

AIRENCE6E-TALKBACK

INSPECT
TEST
10201706

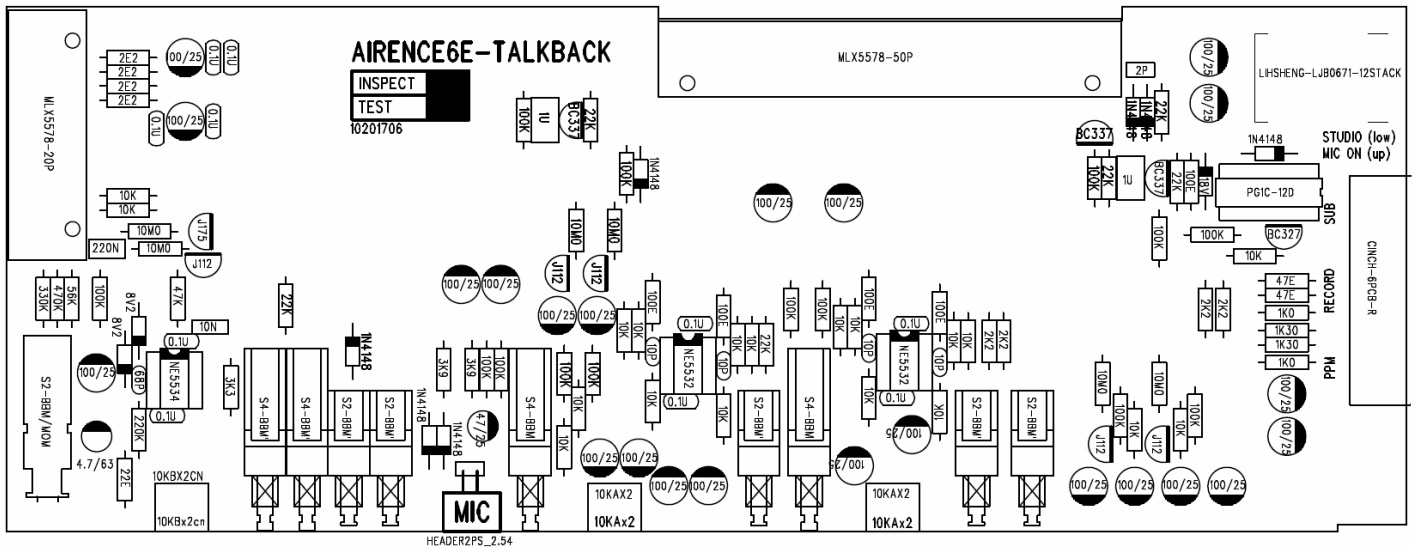

Diode's

| | | |
|--------|---|----------|
| 1N4148 | 7 | 10250342 |
| 18V | 1 | 10250350 |
| 8V2 | 2 | 10250352 |

Weerstanden

| | | |
|------|----|----------|
| 2E2 | 4 | 10350703 |
| 22E | 1 | 10350709 |
| 47E | 2 | 10350713 |
| 100E | 5 | 10350717 |
| 1K0 | 2 | 10350729 |
| 1K30 | 2 | 10350831 |
| 2K2 | 4 | 10350733 |
| 3K3 | 1 | 10350735 |
| 3K9 | 2 | 10350736 |
| 10K | 19 | 10350741 |
| 22K | 6 | 10350745 |
| 47K | 1 | 10350749 |
| 56K | 1 | 10350750 |
| 100K | 14 | 10350753 |
| 220K | 1 | 10350757 |
| 330K | 1 | 10350759 |
| 470K | 1 | 10350761 |
| 10M0 | 6 | 10350776 |

Condensatoren

| | | |
|------|----|----------|
| 10P | 4 | 10400213 |
| 68P | 1 | 10400223 |
| 10N | 1 | 10401253 |
| 0.1U | 10 | 10401241 |
| 220N | 1 | 10400269 |
| 1U | 2 | 10401268 |

Transistoren

| | | |
|-------|---|----------|
| J175 | 1 | 10250017 |
| BC337 | 3 | 10250332 |
| BC327 | 1 | 10250333 |
| J112 | 5 | 10250338 |

IC's

| | | |
|--------|---|----------|
| NE5534 | 1 | 10250306 |
| NE5532 | 2 | 10250307 |

Elco's

| | | |
|--------|----|----------|
| 4.7/63 | 1 | 10400281 |
| 47/25 | 1 | 10400287 |
| 100/25 | 23 | 10400292 |

Schakelaars

| | | |
|------------|---|----------|
| S2-BBM/MOM | 1 | 10550395 |
| S2-BBM' | 7 | 10550414 |
| S4-BBM' | 2 | 10550415 |

Connectoren

| | | |
|--------------|---|----------|
| CINCH-6PCB-R | 1 | 10600--- |
| LJB0671 | 1 | 10600802 |

HEADERS

| | | |
|----------------|---|----------|
| MLX5578-50P | 1 | 106001?? |
| MLX5578-20P | 1 | 10600456 |
| HEADER2PS_2.54 | 1 | 10600505 |
| 2P | 1 | 10600505 |

Potmeters

| | | |
|----------|---|----------|
| 10KBX2CN | 1 | 10300423 |
| 10KAX2 | 2 | |

Div,

| | | |
|----------|---|----------|
| LED3GRN | 7 | 10250386 |
| PG1C-12D | 1 | 10550001 |